

Online beleggersbijeenkomst 7-4-2026

Video:

https://youtu.be/z6VK6o_fzgo

Mold Changing Solutions

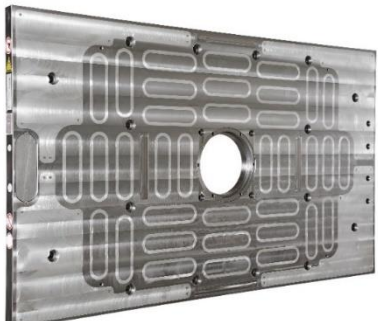

clamping solutions



ejector coupler solutions



transport solutions

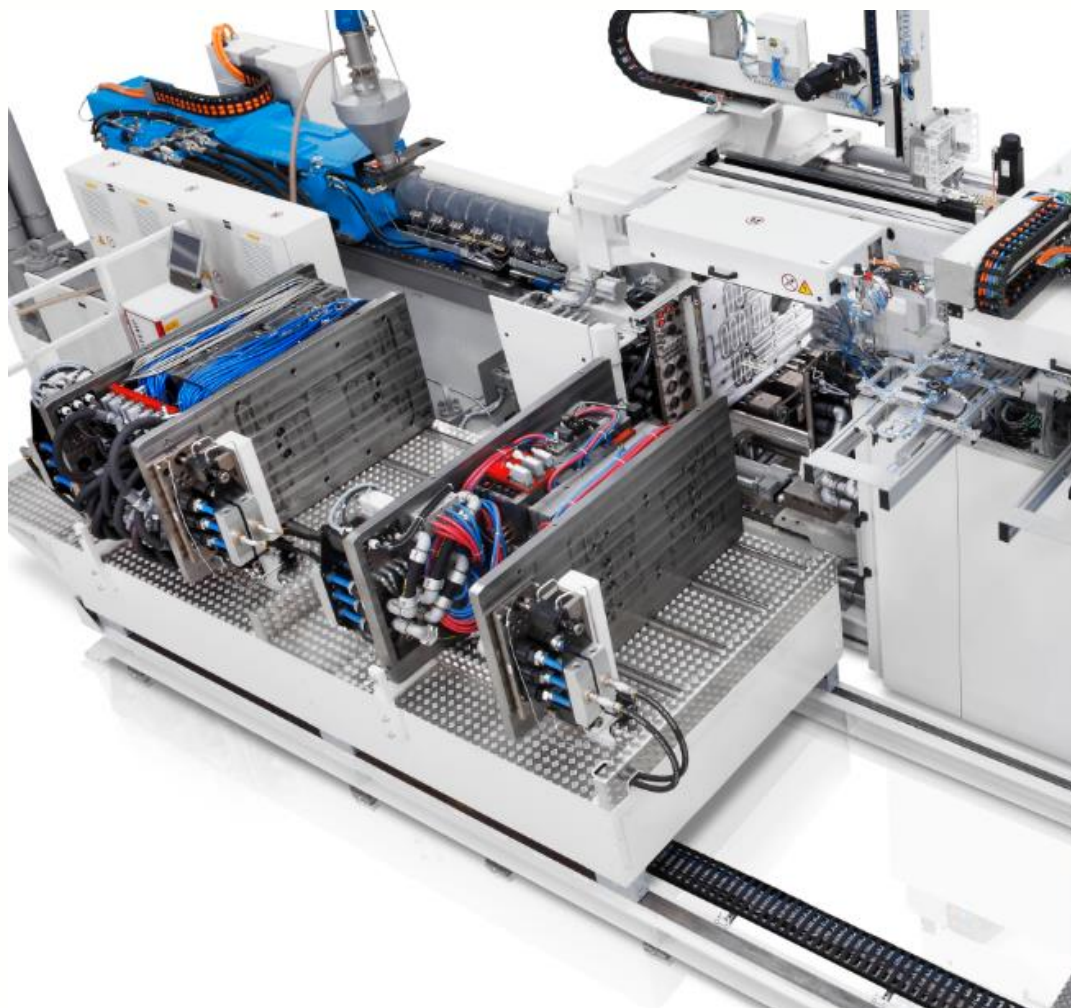

turnkey solutions



couplers solutions



mold & die handling solutions



maintenance solutions

1986 – start als business unit van Enerpac Tool Group

2001 – MBO en start als zelfstandig bedrijf met vestigingen in Nederland en de Verenigde Staten

2005 – Aankoop van know-how van Walker Magnetics voor eigen lijn magnetische spansystemen

2006 – Opening van vestigingen EAS France SARL en EAS Med Srl (Italië) & begin productie van EAS magneetspansystemen.

2007 – Oprichting Suzhou GienkeeEAS Mold & Die Change Systems (EAS China)

2008 – Opening van productie locatie EAS China

2013 – Lancering van productlijn voor wisseltafels voor de kunststof industrie

2015 – MBO door huidige aandeelhouders

2017 – Verhuizing in Verenigde Staten van Milwaukee, Wisconsin naar Greenville, South Carolina

2024 – introductie van magneetspanlijn voor de metaalindustrie

2025 – lancering eigen lijnen van matrijs opslag rekken, transportwagens, wisseltafels voor de metaal industrie en automatisch verschuifbare cilindres voor de metaalindustrie

2025 – “white label” productie overeenkomst met branche genoot voor magneetspansystemen



Onze producten en diensten

- Leverancier van componenten en systemen voor **Quick Mold Change** in de **Kunststof industrie (60%)**
- Leverancier van componenten en systemen voor **Quick Die Change** in de **Metaalstans industrie (20%)**
- Naast deze markten leveren wij dezelfde producten en diensten aan de staalgiet industrie, rotationeel kunststof-giet industrie, rubber industrie en de persgiet industrie
- Wij leveren aan eindgebruikers en machine fabrikanten
- Onze Markten: Europa, Noord- & Zuid- Amerika, Afrika en Azië

Onze klanten



MOD Spancomponenten

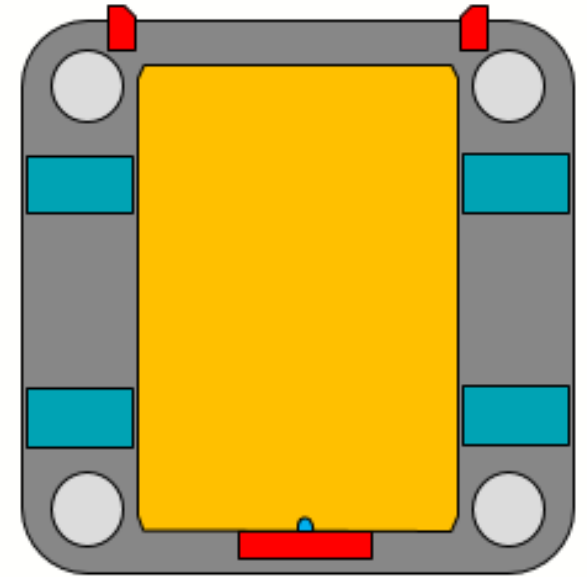
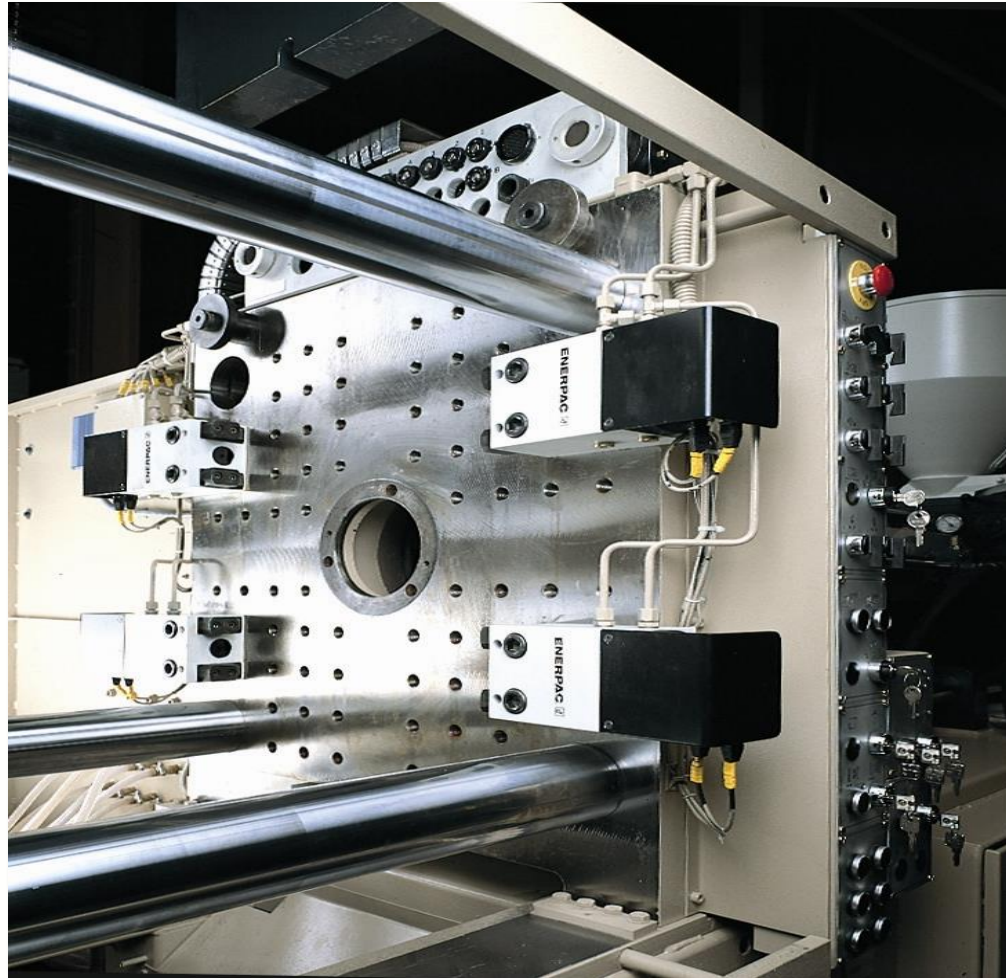
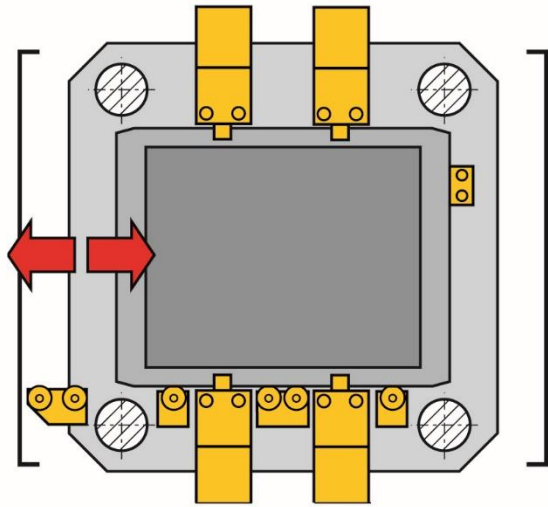

- Standardized Backplate
- Bolt mounted
- Self Locking
- Vertical and Horizontal

Magneetspansystemen

1. Standard Layout
2. Rotational Molding
3. Vertical support – Filler Plates
4. Side Loaded System

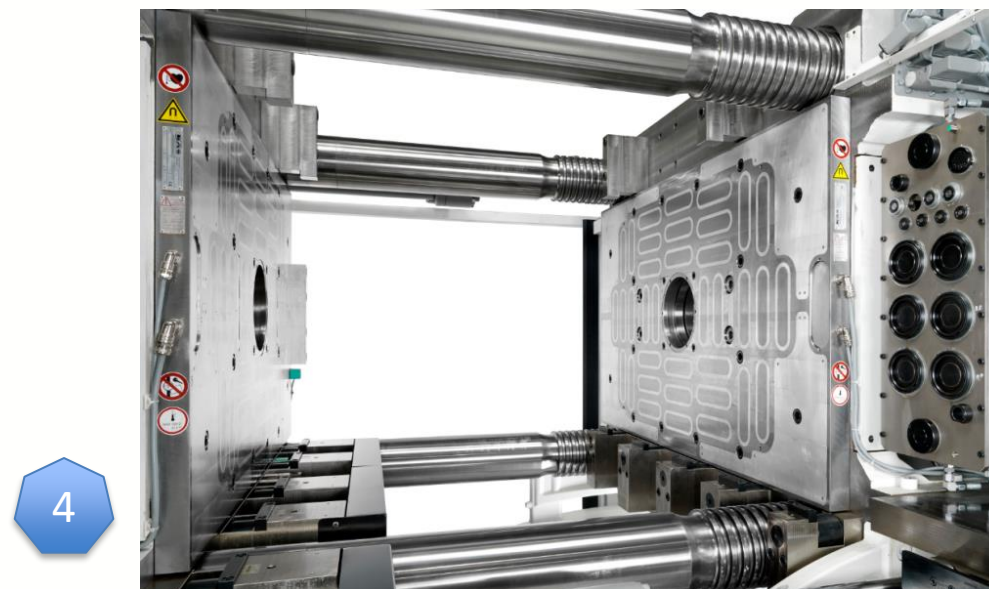
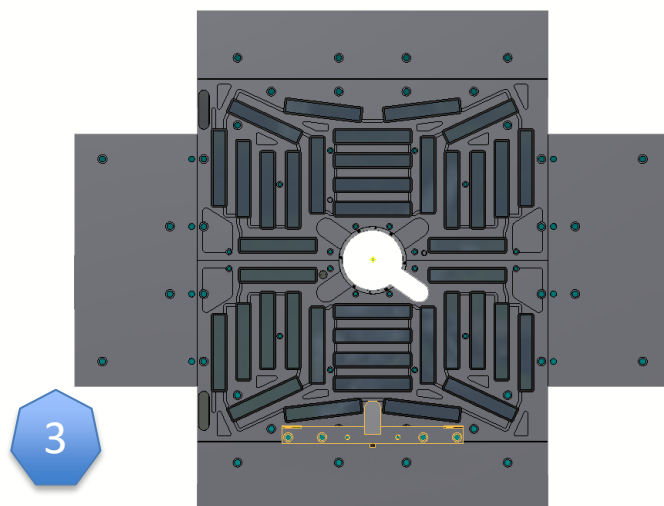
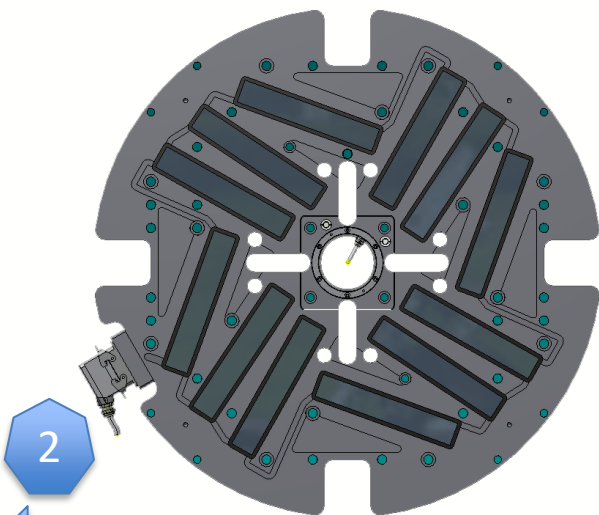
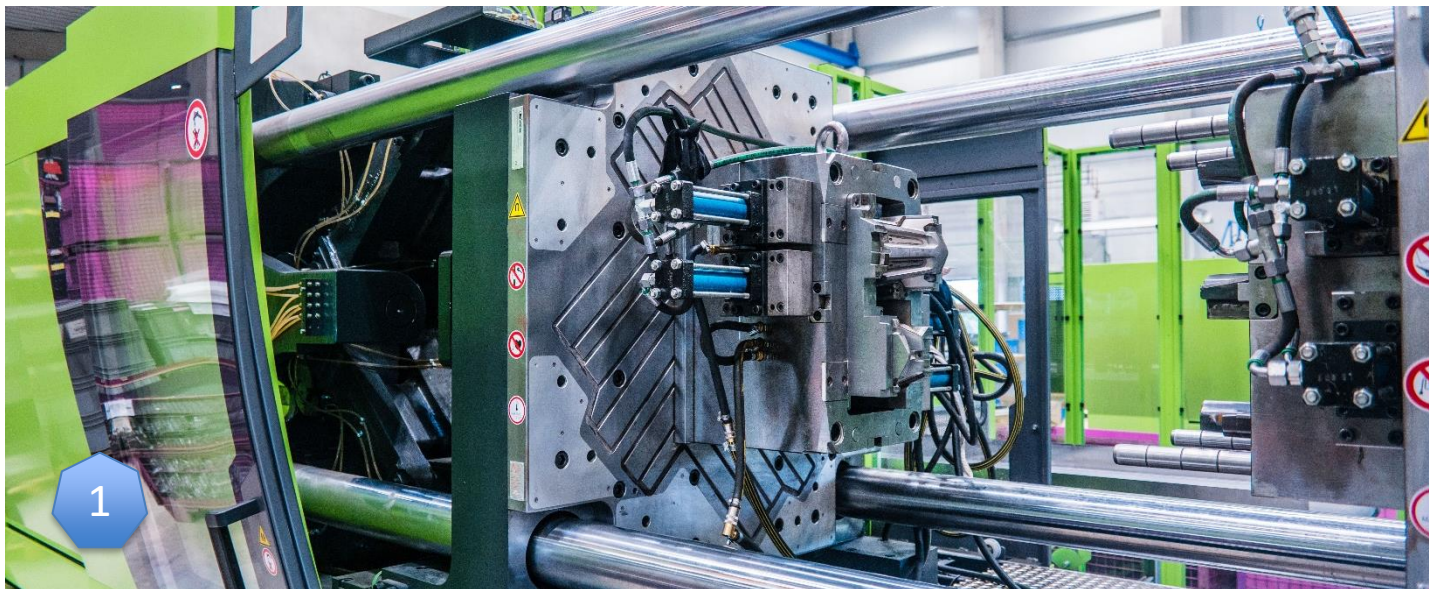

Koppelingen voor:

- Koelingswater
- Hydraulische olie
- Thermo Olie
- Lucht
- Electriciteit
- Temperatuur en druk sensors
- Naderingsschakelaars



EAS Turnkey Solutions: Matrijswisseltafels

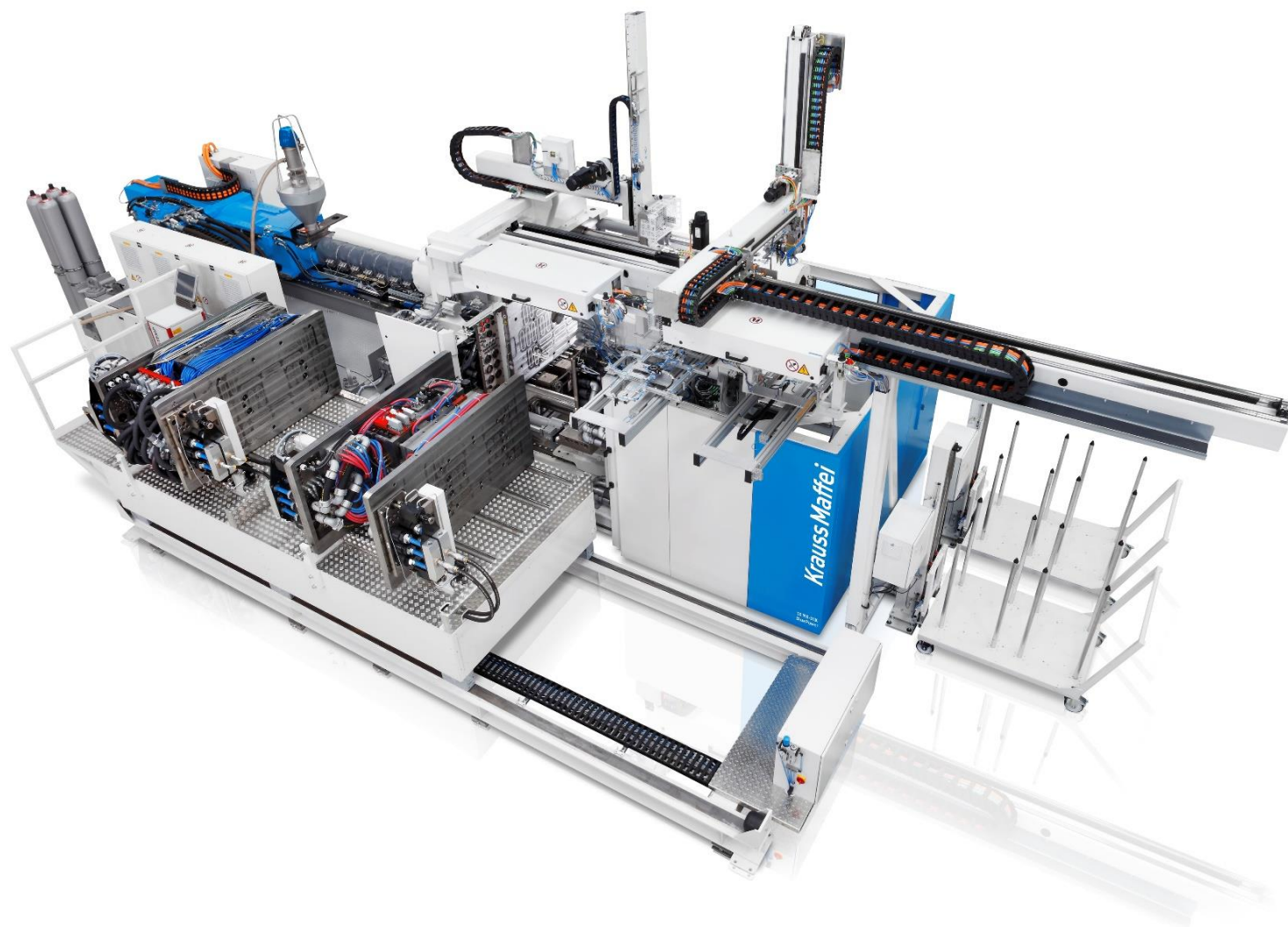

Matrijs Transporter for matrijzen tot 50 ton

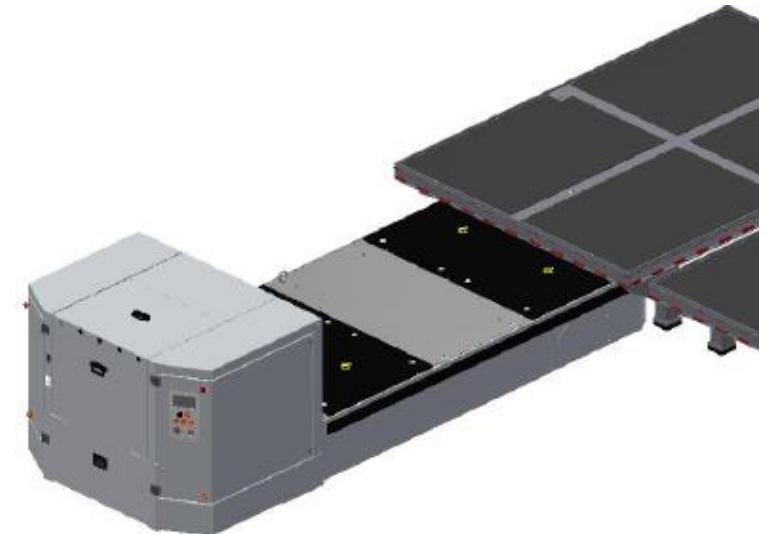
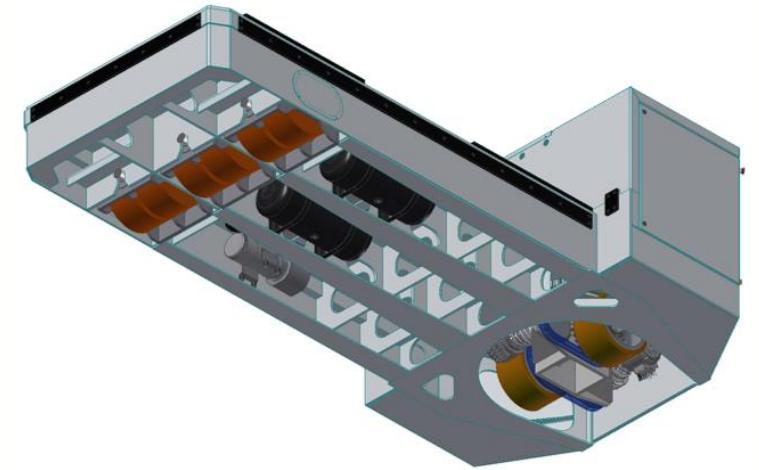

Matrijs Inspectie Eenheid

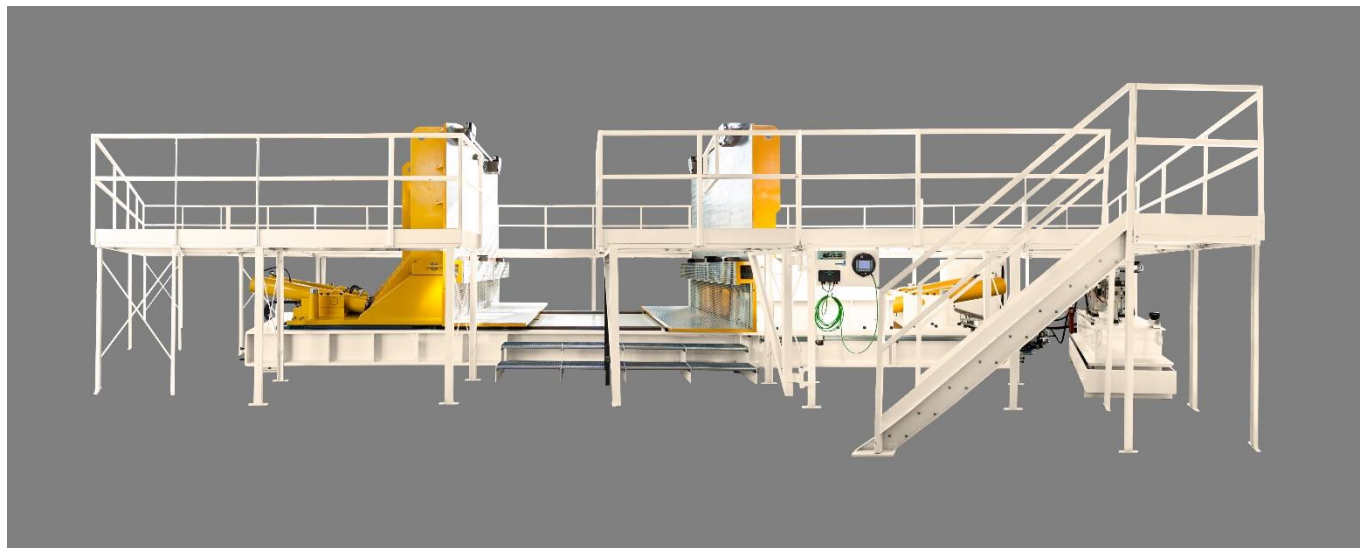

Voor gewichten van 1 – 110 tons



Organogram

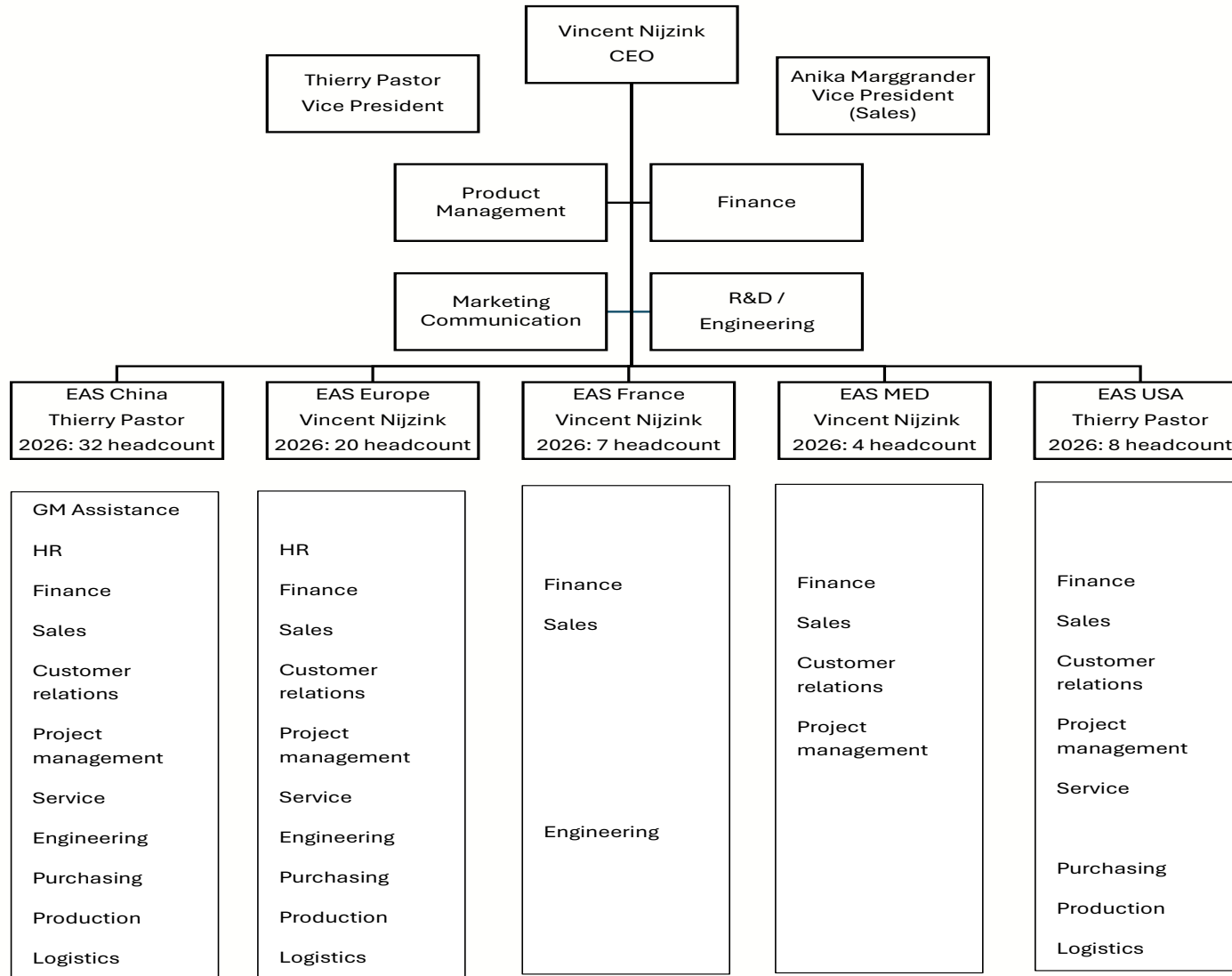

Verkoopnetwerk

- Branch and factory
- Branch
- Office
- Distributor
- Agent

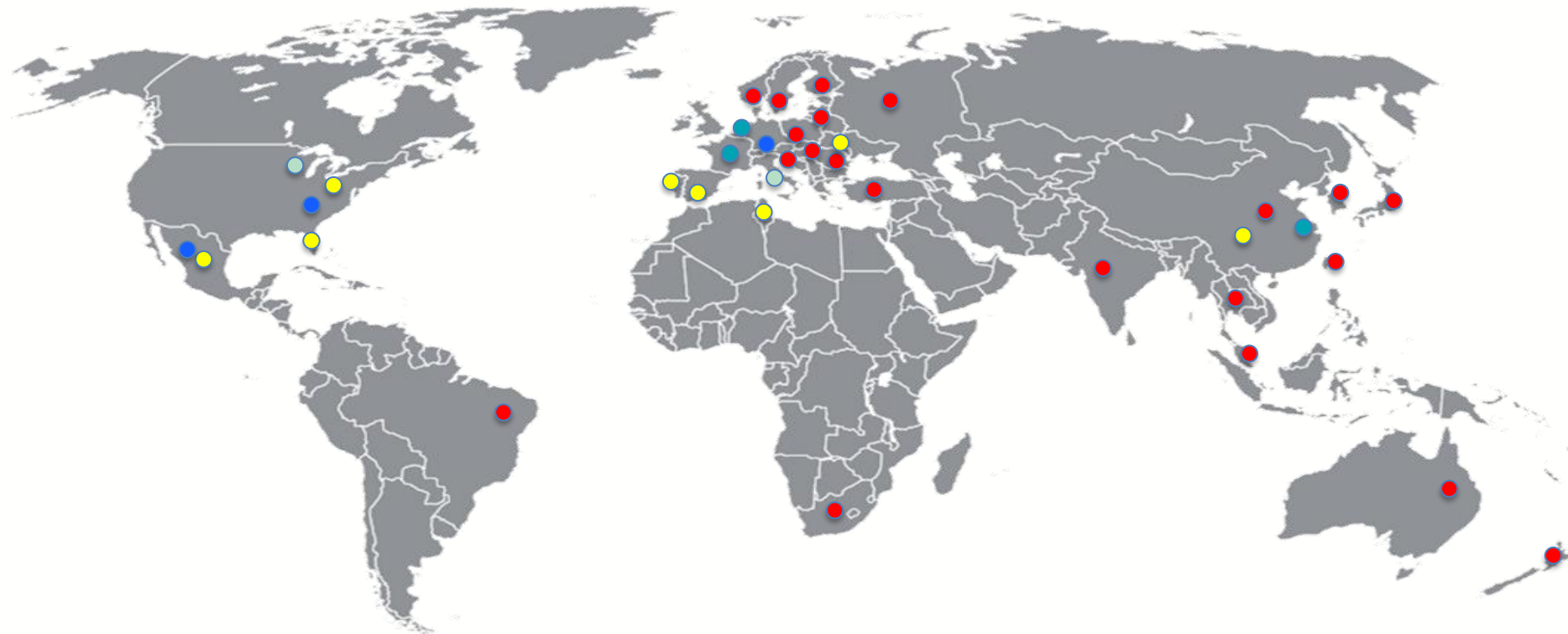

Omzet & verwachting

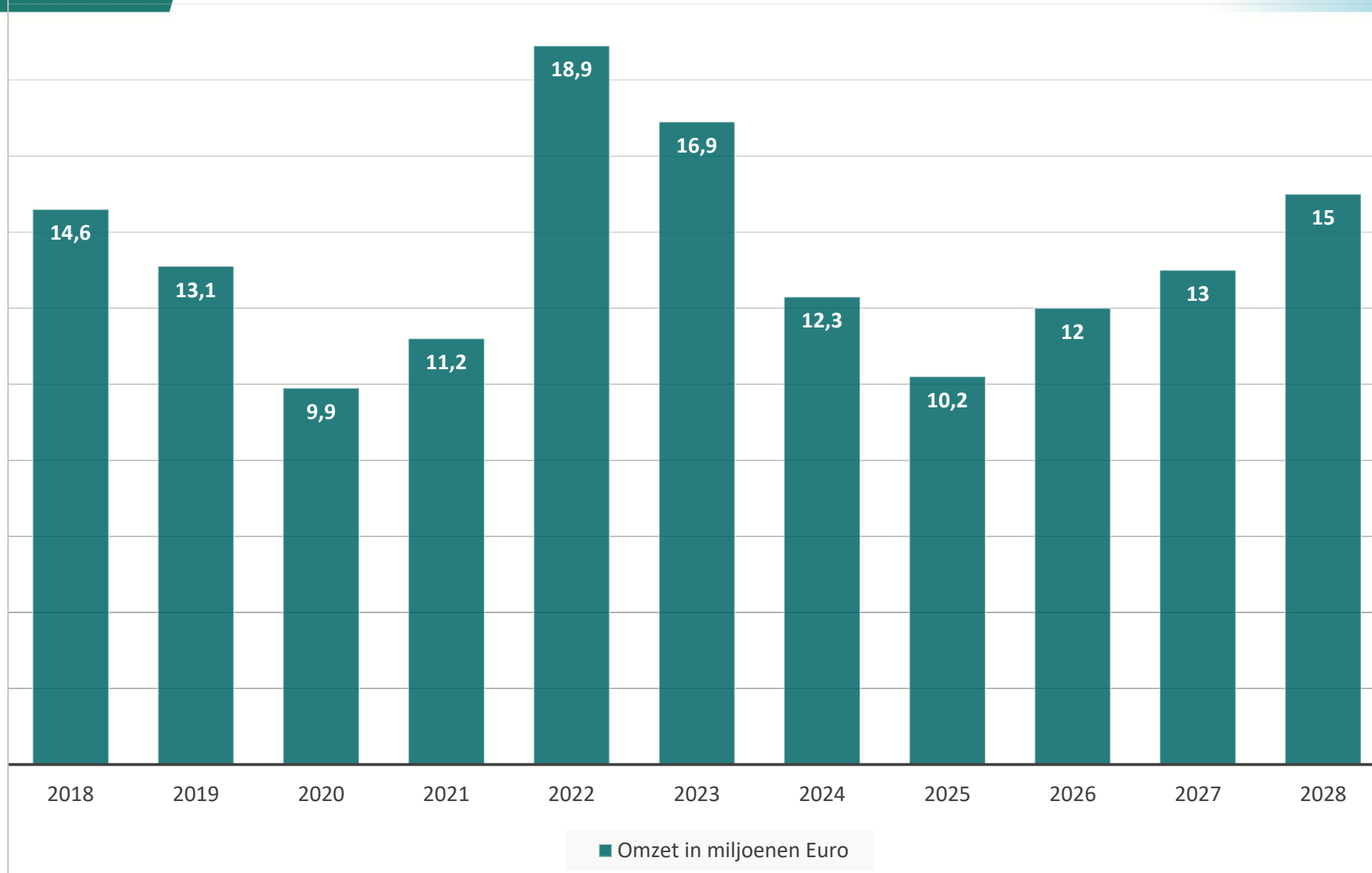

EBITDA*

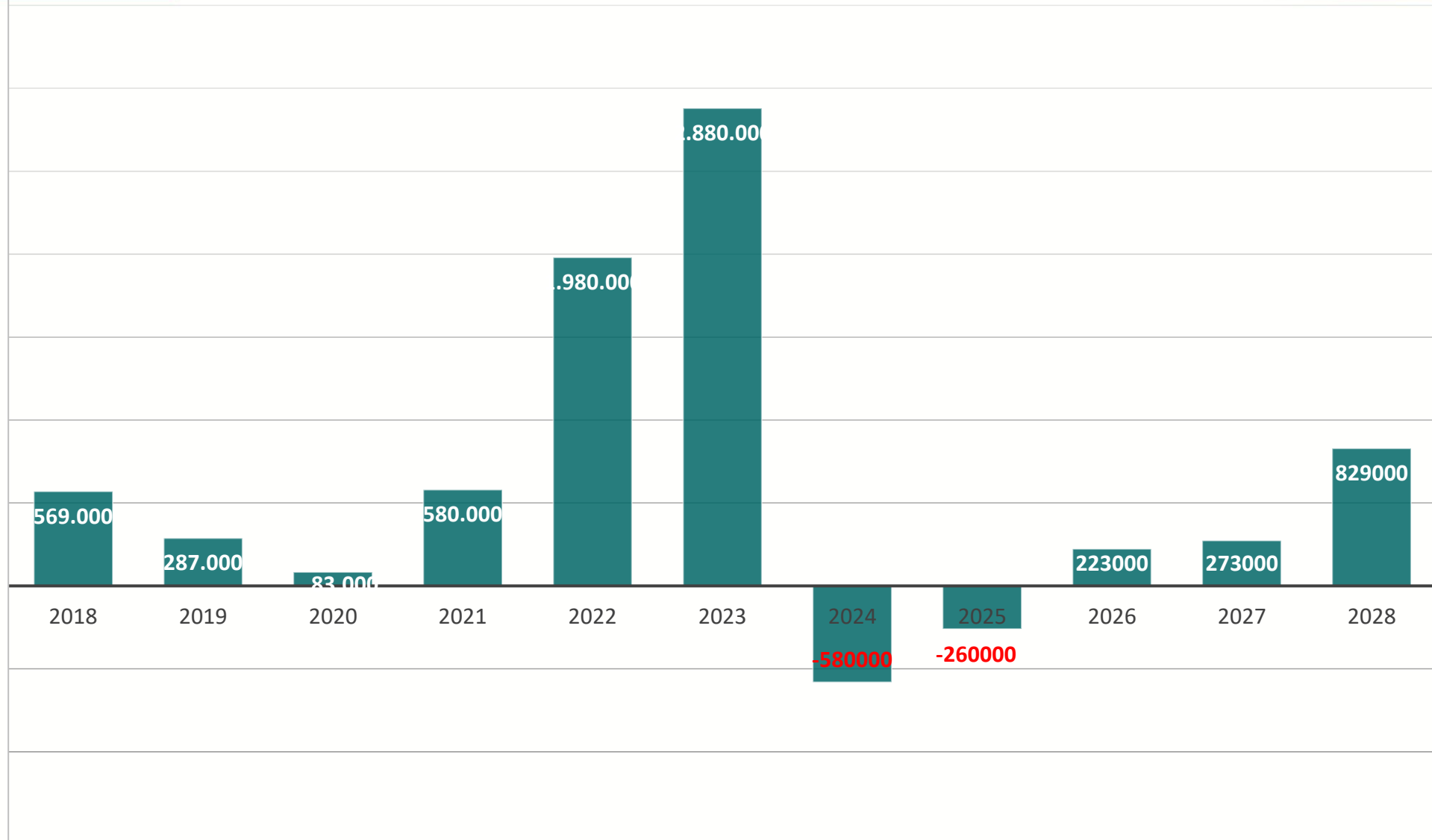

*Earnings Before Interest, Taxes, Depreciation and Amortization

- Terugkeer naar normaal omzet nivo
- Stabiele uitbouw van organisatie
 - Her-oriëntatie verkoop activiteiten
 - Meer focus op standard producten via nieuwe afzet kanalen
- Aanpassingen in de productlijn conform marktveranderingen
- Dit door:
 - Dieptemunt spuitgietmarkt Europa was zomer 2025 – Europese markt trekt aan
 - Protectionisme in Europa & rapport Draghi leiden naar meer investeringen
 - Samenwerking met branchegenoot – white label productie met verwachte omzet van € 3 miljoen jaarlijks
 - Stijgende omzet in Noord- en Midden- Amerika
 - Herstel op Aziatische markten (zichtbaar vanaf Q4 2025)
 - Er is verwachte groei op zowel de kunststofmarkt, metaalmarkt, automotieve markt en de markten van QMC en QDC

Doel emissie

Wij willen maximaal € 1.300.000 lenen van beleggers. Wij willen minimaal € 700.000 lenen van beleggers.

Wij willen het geld van de obligaties gebruiken voor investering in R&D (€ 100.000) en voor het aanleggen van een beperkte voorraad standaardproducten (€ 50.000). Daarnaast wordt een deel van de bestaande vendor loans (€ 300.000) omgezet in obligaties. De rest van het bedrag zal dienen om de verkooporganisatie te versterken en als liquiditeitsbuffer.

Obligaties

Rente: 9% op jaarbasis

Looptijd: 5 jaar

Nominale Waarde: € 100